



Single Pneumatic Heat Press (40x50cm) Model No.: XP7623



CONTENTS

I. Assembly Drawing	2
II. Technical Parameters	2
III. Operating Process	3-5
IV. Trouble Shooting	6-7
V. Trouble Shooting for Transfer Print Quality.....	8
VI. Heating Element Temperature Measurement	9
VII. Electrical Diagram	10
VIII. Exploded Diagram	11-12
Declaration of Conformity	13

I. ASSEMBLY DRAWING

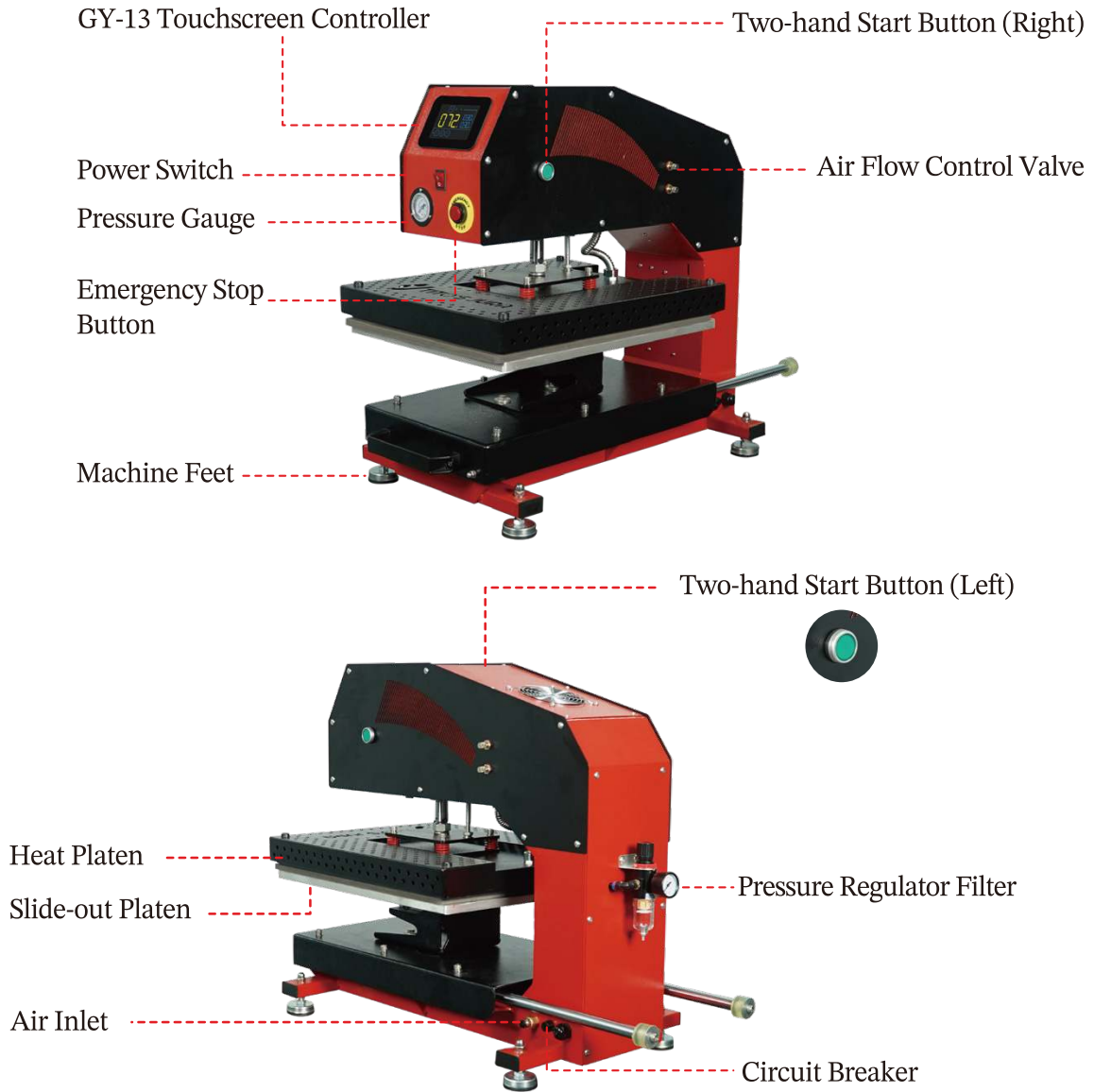

II. Technical Parameters

Model No.: XP7623
Machine Size: 508 x 101x 426 mm
Heat platen Size: 40 x 50 cm
Voltage: 220v/1Phase
Time Range: 0~999s
Maximum Temp: 225°C
Heating Element Power: 1.8KW
Packing Size: 116 x 58 x 87cm
Gross Weight: 125KG

III. Operating Process

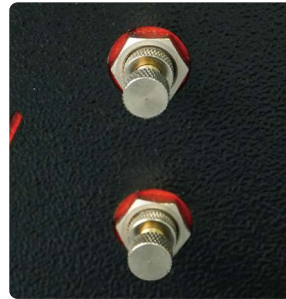

1 Connect the air supply

The pressure value will be displayed on the Regulator Filter Gauge (Range 0-1MPa).

2 Adjust the air pressure

Pull up the knob of the regulator filter to adjust the air pressure (turn clockwise to increase the pressure and counterclockwise to decrease it). It is recommended to set the transfer pressure between 0.4-0.6 MPa. Once you've reached the desired pressure, press the regulator filter knob back down.

3 Filter water from the air

The regulator filter will filter out water from the incoming air, which will be collected in the glass cup beneath the filter. Press the button at the bottom outlet by hand to discharge the water.

4 Adjustment of heat platen's rise and press speed

Adjust the two knobs on the right side of the machine. The upper air flow control valve adjusts the speed at which heat platen rises, while the lower air flow control valve adjusts the speed at which heat platen presses down. You can adjust these settings according to your needs (turn clockwise to decrease speed, counterclockwise to increase speed). After making adjustments, tighten the screws near the machine cover to lock the settings. *(Note: The machine is pre-set with suitable speeds, and it is not recommended to adjust these settings.)*

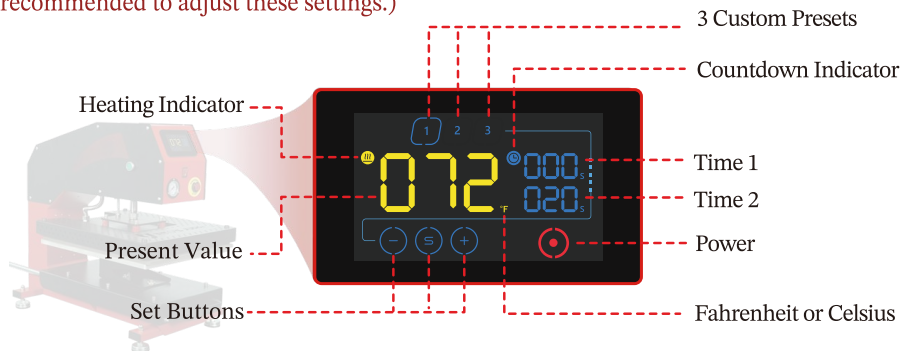

Touchscreen Controller



Present Temperature



3 Custom Presets



Power Indicator



Set Buttons: Use the “-” and “+” buttons to set your desired temperature or time. “=” is for switching between setting modes.



Two Sets of Time: The first is displayed above, and the second is below. After the first countdown ends, the heat platen automatically opens. Then use “Two-hand Start Button” to press down the heat platen to start the second countdown. In case you want to adjust the setting time, wait until the second countdown ends, or set the first set of time to 0 and use only the second set of time.



The Power ON/OFF Switch on the side of the press, turn the Power Switch ON.



The controller is on. Three custom presets flash. Select one of custom preset to start your setting.

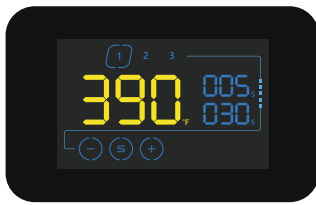

Press the “S” button to enter the temperature setting. Use the “+” and “-” buttons to set your desired temperature. Press “S” to save your setting.



We are now going to set the 2 countdown times. Use the “+” and “-” buttons to set your desired times. Press “S” to save your setting. Generally “Time 1” for preheat, and “Time 2” for heat transfer time. Always follow your heat transfers recommendations.

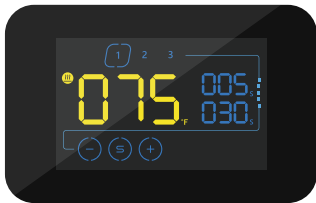

The “H” indicator is flashing that the machine is in the heat up mode. When the temperature reaches the set value, the buzzer sends sound intermittently, indicating that the heat press machine is ready to press.

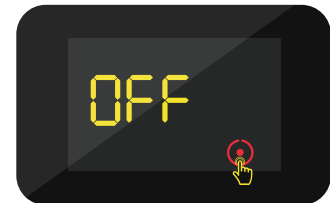

Auto-off feature: If there is no operation within the set sleep time (150 minutes), the screen will display “OFF”. You can restart the controller by clicking “STOP”.



Turn OFF the power switch when not in use.

Exchanging the lower platen



Draw out the lower platen. Pull and rotate the indexing pin to release the lower platen.



Take out the lower Platen.



Insert the new lower platen you want to replace.



Rotate the indexing pin, insert and lock it.

When using your heat press machine, always follow these basic safety precautions to ensure safe operation.



1. Read all instructions carefully before use.
2. Use the heat press only for its intended purpose—pressing materials using heat.
3. Prevent electric shock by avoiding contact with water or liquids.
4. Unplug safely by grasping the plug, not the cord, when disconnecting from the outlet.
5. Keep cords away from hot surfaces and allow the machine to cool completely before storing it.
6. Do not use the machine if the cord is damaged or if it has been dropped or damaged. If repairs are needed, take it to a qualified service technician to avoid risks of fire, shock, or injury.
7. Always disconnect the power before cleaning, servicing, or performing maintenance on the machine.
8. Supervision is required for anyone using the heat press, especially children or those with reduced physical, sensory, or mental capabilities. Never leave the machine unattended while connected.
9. Avoid burns by not touching the hot metal parts or the heated platen during use. Wear heat-resistant gloves.
10. Do not overload electrical circuits. Avoid operating other high-voltage equipment on the same circuit as the heat press.
11. If an extension cord is needed, ensure it is rated for at least 20 amps to prevent overheating. Position the cord to avoid tripping or pulling hazards.
12. Keep hands clear of the upper platen during lock-down to avoid injury from the machine's pressure.
13. Place the heat press on a sturdy, suitable stand to ensure stability during operation.
14. Keep the work area clean and free of obstructions to avoid accidents.
15. Regularly inspect air hoses and connections on pneumatic models for any leaks or damage.

4. Printing methods

Step 1: Make sure the cord is connected well to the wall socket. Place the object (i.e. T-shirt) on the press bed, then put transfer paper with image facing down onto the object. Adjust the pressure to your requirement and turn on the power.

Step 2: Set the temperature and time required (see above) and the temperature will start to rise.

Step 3: When the temperature has risen to the setting required, the buzzer will sound; you can then lower the heat platen (in the meantime the buzzer will stop). This starts the transfer cycle.

Step 4: Then the time counter is on, once time is up, open up the upper heat platen.

Step 5: Consult the Transfer Paper instructions on whether to peel cold or hot. Here are suggested Pressing time guidelines for different transfer papers:

- Ink-Jet Transfer Paper (fabric) 14-18 seconds.
- Sublimation Transfers (onto Fabrics) 25-30 seconds.
- Sublimation Transfers (onto FR-Plastic/Woods) 60-70 seconds.

5. Recommendations:

1) Ceramic tile transfer: (Mugs & Plates transfer is similar)

- Set temperature: 180°C.
- Set time: 15 seconds.

2) T-shirt transfer:

- Set temperature: 180°C.
- Set time: (chemical fibre use for sublimation transfer paper:- 30 50 seconds; pure cotton use for T-shirt transfer paper: 10-20 seconds).

3) Aluminium sheet transfer:

- Set temperature: 180°C.
- Set Time: 45 seconds.

Step 6: When the temperature rises to the set temperature, the buzzer sounds and the heat platen lowers down, the buzzer then stops, and the transfer cycle starts.

Step 7: Once the transfer cycle is finished the buzzer will sound again. The heat platen will then open automatically, and the buzzer will stop.

Step 8: Pull the draw forward using the Slide Out Drawer Handle.

PLEASE NOTE:

1) Switch off the machine and unplug the power cord when the machine is not in use.

2) Suitable air pressure range is 0.4-0.5Mpa (75-80Psi), setting the air pressure too high can break the machine, Setting the air pressure too low will lead to spoiled work and erratic machine operation.

3) It is recommended that the press should be powered off for 1-2 hours after it has been in continuous operation for 6-8 hours.

▲ When you finish the transfer process, there are two important matters that will need your urgent attention.

4) After use please DO NOT shut off the power immediately. The heat platen is very hot now after the machine has been in operation for any length of time. The operator should initially press the "OK" button after they have finished their last heat transfer cycle, this will prevent the heat platen from heating, but the fan in control box is still spin helping to cool down the heat platen. The power should be kept on for around 20-30 minutes after the transfer process is finished.

5) After use please DO NOT shut off the air pump immediately. The heat platen is very hot now after the machine has been in operation for any length of time. If you shut down the air pump, the hot heat platen will lower and rest on the lower platen which can lead to burning of cotton pad. The air pump should be kept on for around 20-30 minutes after the transfer process is finished.

IV. Troubleshooting

1. The machine will not work after you turn on the power.

- 1). Check the plug is connected well or that it is not broken.
- 2). Check the power switch or digital controller is not broken.
- 3). Check the fuse is not blown.
- 4). Indicating light is on, but no display on screen, check the 5 cable of Railway transformer. If it is loose, this indicates that the problem is poor connection. If it is securely connected, it indicates that the Transformer is faulty.

2. The display screen is working well, but the heat platen temperature does not rise.

- 1). Check whether the thermocouple of the heat platen is secure. If the thermocouple is loose, the display will show 255°C and the machine will keep beeping.
- 2). Check if the indicating light of the solid-state relay is on. If not, check if the relay or digital controller is broken.
- 3). If you have already replaced the solid-state relay for a new one but the heat platen will still not heat up, then check to see if the heat platen is faulty or the heat platen's power cable is loose, you may need a new heat platen.

3. The heat platen works well, but suddenly the display screen shows 255°C.

- 1). Check whether the thermocouple is secure.
- 2). If the thermocouple is firmly attached but the controller still shows 255°C, then it is faulty.

4. The machine is heating between 0~180°C, but the display number jumps to above 200°C or 300°C suddenly, or the numbers on the display jump irregularly.

- 1). Check whether the thermocouple of the heat platen is firmly attached.
- 2). If the thermocouple is OK, It shows that the program of the digital controller is broken. You will need to replace it for a new controller.

5. The temperature is out of control: Set to 180°C, but the actual temperature is above 200°C.

- 1). This indicates that the solid-state relay is broken/ out-of-control; You will need to replace the relay.
- 2). Alternatively, the digital controller could be faulty with an open circuit providing constant power; You will need to replace the controller.

6. The setting temp and time becomes abnormal after you have replaced the heat platen.

- 1). Please reset the temp and time according to this operators' manual.

7. Maintenance.

- 1). In order to prolong the machine's service life, you should regularly lubricate all mechanical joints with light machine oil.
- 2). Care should be taken to protect the heat platen whenever the machine is not in use. This will prolong the life of the platen and help to keep the image quality of your work high.
- 3). The machine should be stored in a dry place.
- 4). If you are not able to solve your problem, please contact your authorised dealer for technical support.

8. The following checks should be carried out at regular intervals by a qualified and competent person:-

- Electrical connections
- Pneumatic system for air leaks
- Pneumatic system for lubrication
- Mechanical moving parts

V. Trouble shooting for transfer print quality

1. If the print colours are pale: the temperature is too low / the pressure is not correct / or the transfer has not been pressed for long enough.
2. If the print colour is too brown or the transfer paper is almost burnt: reduce the setting temperature.
3. If the print is blurring: too much transfer time causes proliferation of the ink.
4. If print colour is different/ partial transfer effect is not good enough: the pressure is not enough / or the transfer has not been pressed for long enough / or poor quality transfer paper.
5. If transfer paper sticks to the object after transfer: the temperature is set too high/ or poor quality printing ink.

VI. Heating Element Temperature Measurement

Testing of the Heating Element for temperature consistency or fault condition should only be undertaken after consulting a qualified engineer, and then only using a wired Digital Thermometer (***please see note below**).



***Please Note:**

The Digital Thermometer with external probes suitable for surface, air and immersion/penetration measurement, which is required for all Heat Presses Direct heat presses.

Laser Thermometers only measure air surfaces which can be misleading due to currents of hot air floating on the surface of the heating Element.

VII. Electrical Diagram

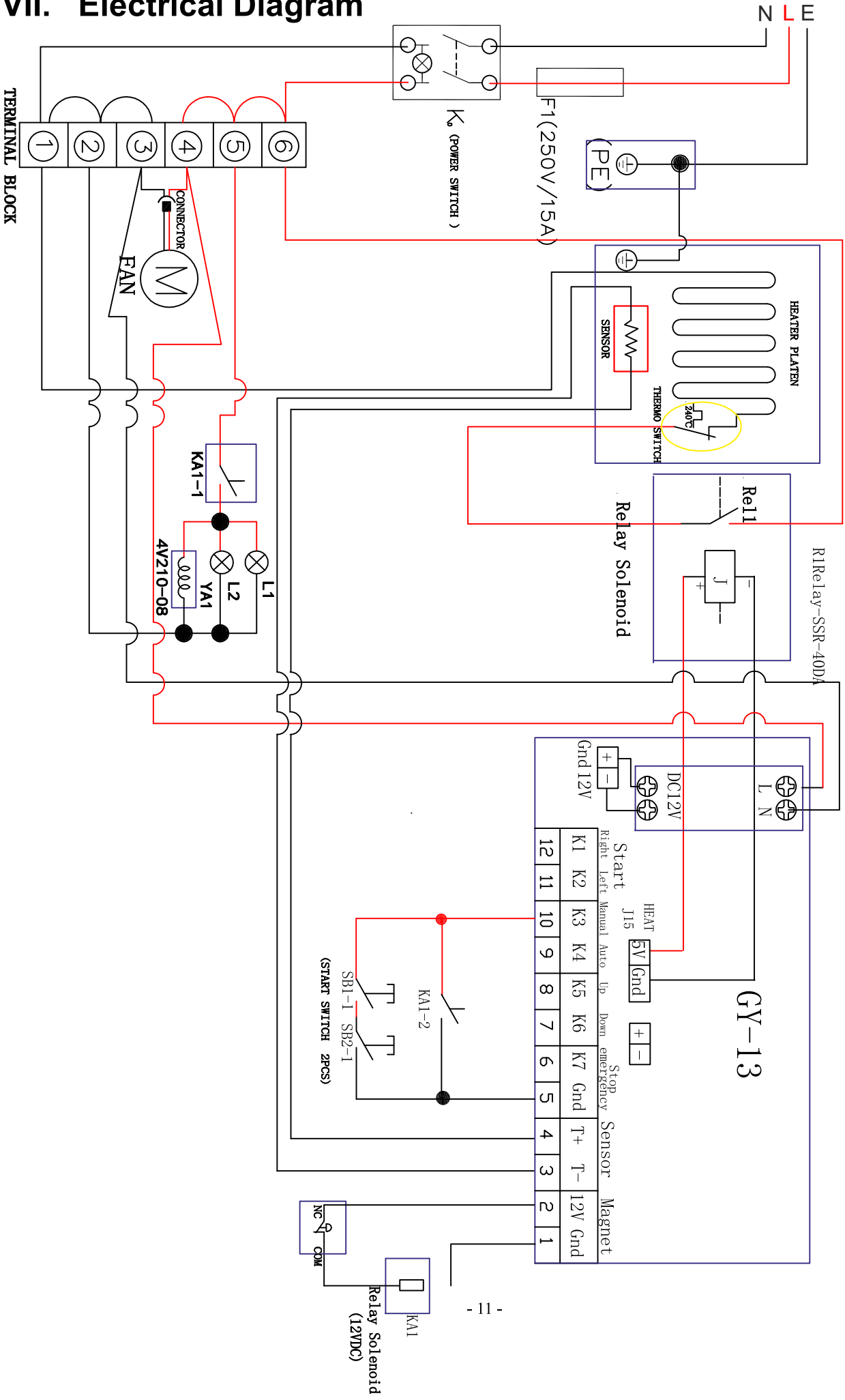



12	Rocker Switch	1
13	Emergency Stop Button	1
14	Adaptor Plate	1
15	Spring	4
16	Adaptor Plate	1
17	Antiscald protective metal cover	1
18	Heat Platen 40x50cm	1
19	Heat Platen 40x60cm	1
20	Print Bed	1
21	Slide Out Drawer Handle	1
22	Slide Rail	2
23	Slide Rail Buffer	2
24	Rubber Feet	2
25	Machine Frame	1
26	Air Valve	1
27	Electromagnet Valve	1
28	Air Hose Connector	2
29	Transformer	1
30	Solid-State Relay	1
31	Electromagnetic Driver Board	1



Charterhouse Holdings PLC

DECLARATION OF CONFORMITY

Application of Council Directives:	European Low Voltage Directive (LVD), European Machinery Directive (MD), Electro Magnetic Conformity (EMC)
Standards to which Conformity is Declared:	(MD): <u>EN ISO 12100:2010 2006/42/EC Annex1</u> (EMC): <u>EN 61000-6-2:2019</u>
Manufacturer's Name:	Charterhouse Holdings PLC
Manufacturer's Address:	Oakridge Park, Trent Lane, Castle Donington, Derby DE74 2PY United Kingdom
Type of Equipment:	Single Table Pneumatic Heat Press
Standards Compliance:	 
Model Number:	<u>XP7623</u>
Serial Number:
Year of Manufacture:

I, the undersigned, hereby declare that the equipment specified above conforms to the above directives and standards.

Place: Castle Donington, United Kingdom

Signature: M. S. Carter

Date: 15th June 2023

Full Name: Miles Carter

Position: Chief Executive